

Stromlaufplan R 43 / R 53-1100

230-240V / 50 Hz

ab Masch. Nr. 8240

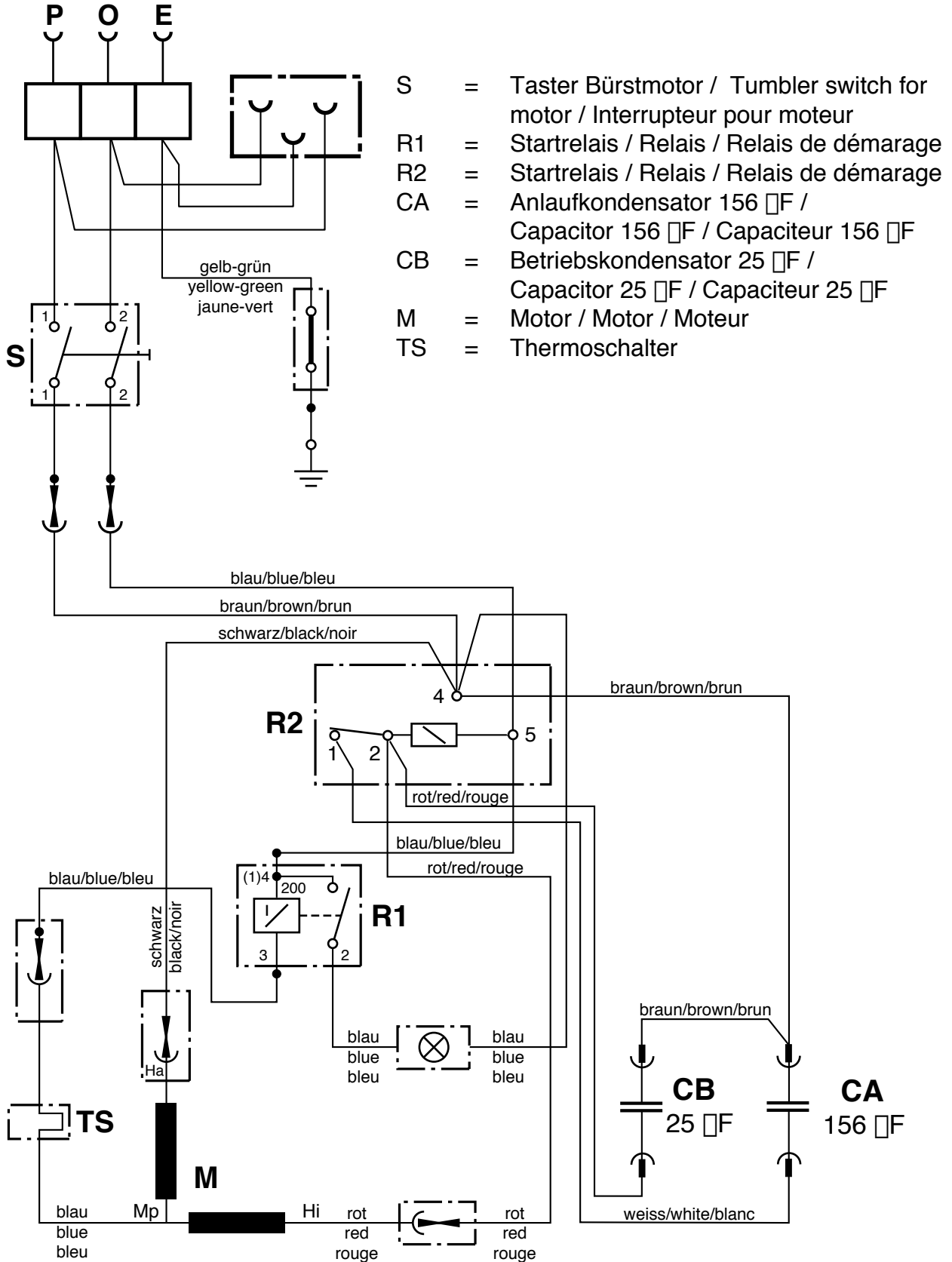

R 43 -900
Stromlaufplan

ab Masch. Nr. 8240

Pos.	Bezeichnung	Art. Nr.
CA	Anlaufkondensator 156 μ F	782.307
CB	Betriebskondensator 25 μ F	P...385J
M	Motor	785.200
R1	Startrelais 2CR105-196	6630440
R2	Startrelais	P...355C
S	Taster Bürstmotor	6650454
TS	Thermoschalter	